

PAPER • OPEN ACCESS

The application of acoustics for sample manipulation and delivery at X-Ray Light Sources

To cite this article: Peter Docker *et al* 2025 *J. Phys.: Conf. Ser.* **3010** 012146

View the [article online](#) for updates and enhancements.

You may also like

- [A bi-periodic undulator for SOLEIL II: concept and prototype](#)
A. Potet, R. Belkhou, P. Berteaud *et al.*
- [Advanced X-ray Pixel Detector \(AXPiDe v2.0\): new modular multichannel detector based on SDD available at the XAFS beamline of Elettra](#)
G. Agostini, D. Cirrincione, M. Antonelli *et al.*
- [Progress in the Development of Multi-Element Monolithic Germanium Detectors in LEAPS-INNOV Project: Insights from Detector Performance Simulation](#)
N. Goyal, S. Aplin, A. Balerna *et al.*



The Electrochemical Society
Advancing solid state & electrochemical science & technology



249th
ECS Meeting
May 24-28, 2026
Seattle, WA, US
Washington State
Convention Center

Spotlight Your Science

**Submission deadline:
December 5, 2025**

SUBMIT YOUR ABSTRACT

The application of acoustics for sample manipulation and delivery at X-Ray Light Sources

Peter Docker^{1*}, **Danny Axford**¹, **Mark R. Warren**¹, **Beth Galtry**¹, **Mark Frogley**¹, **Gianfelice Cinque**¹, **Gabriel Leen**^{2,4}, **Nikolay Pavlov**², **Romain Bordes**⁴.

¹ Diamond Light Source, United Kingdom

² PolyPico Technologies, Ireland

³ Chalmers University, Sweden

⁴ University of Limerick, Ireland

*E-mail: Peter.docker@Diamond.ac.uk

Abstract. The latest developments in acoustic technology and their integration of standing waves offers the potential to eject and trap tiny amounts of both liquid and solids with precision and stability in free space. This is appealing for experimenters at Light Sources who are traditionally relying on the use of containers or on the manual attachment of the samples to solid supports for analysis with X rays or IR. Here we present a brief overview of applications of acoustics and levitation for sample manipulation and delivery currently under investigation at Diamond Light source.

1. Introduction

Diamond Light Source, the UK's 3rd generation light source, is actively exploring acoustics and standing waves for sample manipulation and delivery. In addition to synchrotron beamline use, further applications at X-ray Free Electron Laser sources (XFELs) and Cryogenic Electron Microscopy systems (CryoEM) are being explored. Sound is being exploited in two key ways: the first is to use acoustic energy to eject and deliver picolitre drops, in one example containing protein crystals in the range of 5-50 μ m, at a repetition rate up to 50KHz on demand; the second is the use of discrete transducers to create 'acoustic traps', areas of low pressure surrounded by high pressure, which levitate the sample in free-space.

The acoustic ejection system supplied by PolyPico Technologies Ltd. is an effective solution for filling the acoustic levitation traps with sample material [1]. PolyPico's technology has been exploited in other similar applications, including deposition of substrate for XFEL experiments [2], loading grids for automated sample delivery both at Diamond Light Source and XFELs [3], supply sample directly on demand at both Synchrotrons and XFELs [4] and to automate high speed filling of TEM grids for CryoEM. This last application is part of ongoing work at Diamond.

Acoustic levitation systems can manipulate samples in both liquid suspension and as solid form and to present them to the beam for analysis. Three examples will be discussed in this paper namely Tynlev, SuperLev and a commercial system known as Acoustofab. The two former systems are mature enough to have both been used to successfully collect data on several beamlines. The Acoustofab, as a novel device, is in its infancy in terms of application to experiments at Light Sources but the potential it offers regards controlled delivery and merging of both liquids and solids warrants its inclusion here. The use of the acoustic delivery and



levitation systems together creates the exciting potential for experiments where mixing is fundamental, e.g. adding reagents to crystalline samples prior to beam exposure, to perform time-resolved X ray diffraction experiments. Light activated experiments can also be carried out, as well as reactions requiring heating, creating a ‘virtual test-tube’, and enabling containerless biology, where chemistry can take place in free space, free of contamination and with minimal attenuation for data collection.

The following sections describe the current state-of-play in the application of acoustics for sample manipulation at Diamond Light Source across a range of scientific techniques.

2. PolyPico Piezo-Acoustic sample delivery System

PolyPico Technologies Ltd. is a commercial venture, which has developed several acoustic sample delivery systems capable of delivering micro-drops of sample material, with a volume as low as 20 pico litres and at delivery rates ranging from drop-on-demand up to delivery rates of over 50,000 samples per second. Additionally, PolyPico supplies a range of desktop bio-printers, and exotic micro-drop manipulation devices. Unlike most other micro-drop dispensing technologies, the micro-drops are ejected from a disposable polymer cartridge, eliminating the possibility of cross-contamination between samples and allows for the changing of samples in a matter of seconds. PolyPico have tailored dispensing systems for XFEL / Synchrotron instrumentation which can be synchronised with the beam lines system to enable sample delivery at time intervals relevant to X-ray pulses or detector readiness.

PolyPico systems have been used on Diamond Light Source VMXi beamline to directly deliver sample to the beamline, to add substrate to time resolved XFEL experiments to initiate reactions and to fill acoustic levitation devices such as the Tynlev and SuperLev. Detailed information on how the system produces and ejects the drops can be found in this reference [1]. A further recent development of the PolyPico technology is the ability to electrosteer the drops emitted from the head so they can be accurately placed on a substrate.

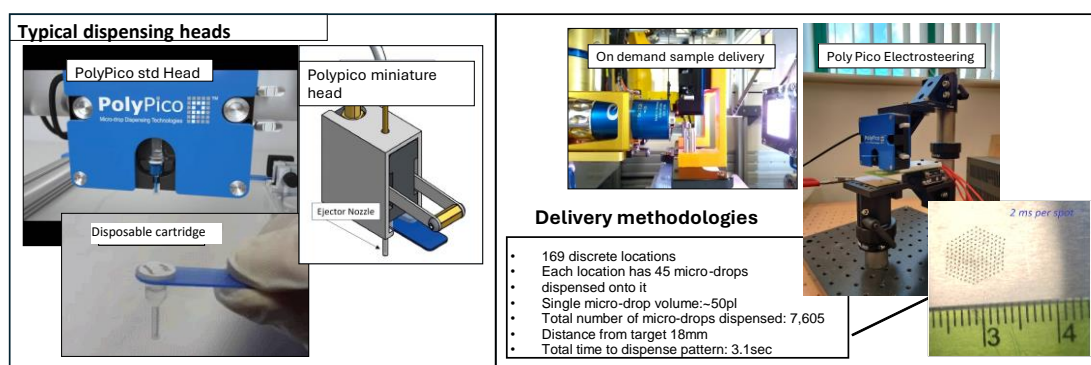

Figure 1. Left, PolyPico dispensing heads, Right, Applications of the technology

This variant to the technology was developed for a call for highly efficient filling of TEM grids for Cryo EM systems. Relatedly, with a standard head and fast actuated motion stages, a PolyPico system can efficiently fill fixed-target sample delivery systems developed at Diamond [2].

3. Acoustofab system for manipulation in 3D space

Acoustofab are a startup at University College London (UCL) producing a multi access acoustic levitation system [5]. The system can move solids and liquids anywhere within the space between the two arrays of 40KHz transducers, used most typically for intruder alarms and reversing sensors in cars. Each transducer must be addressed in timing and amplitude to create pockets of low pressure where the sample will sit and be transported. By addressing these transducers with a fast computational algorithm developed at Acoustofab, samples can be moved at velocities close to 8m/s. Current work is being carried out to develop the software further to handle smaller sample sizes which we envisage being particularly suitable for mixing experiments for time resolved experiments at Synchrotrons. Figure 2 shows the device and a snapshot of some drops of water being suspended and translated by the system.

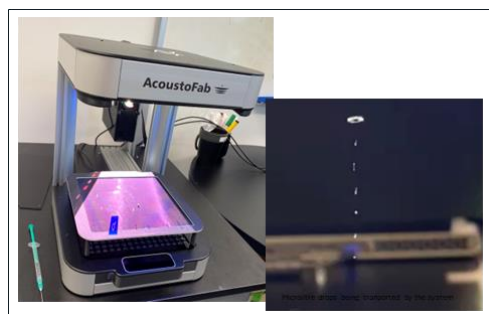

Figure 2. Left, Acoustofab hardware (for reference the arrays of transducers are 300mm apart. Right, close-up image of drops levitated by the system (large drop is 2 μ l and the small ones 30nl).

4. TinyLev, the original acoustic levitation system

TinyLev was developed by Marzo et al [6] and utilises standard 40KHz transducers to suspend samples via the generation of areas of low pressure where sample can be suspended. By exploiting a spherical geometric arrangement where two groups of emitters are facing each and mechanically compatible with the timing delays of the transducers, spatially separated acoustic traps can be produced without the need to address all the transducers individually. This way, the control over the phase of the transducers enables a controlled phase shift in the driving frequency, allowing the system to move samples up and down along a single axis. This architecture greatly simplifies requirements for system operation and with electronics developed at Diamond and a variable power supply, the trap location can be moved up and down and the trapping strength can be varied. Thus, allowing controllable, containerless sample delivery into, and out of an X ray beam.

To date using this system has been used on the microfocus MX beamline I24 where complete diffraction data could be obtained from a levitating 2.5 μ L drop containing an estimated 4-6 Lysozyme crystals with length dimensions on the order of hundreds of μ m [7]. The drop was positionally stable on the beam during an acquisition of 5000 frames over 50 seconds. The diffraction data analysis indicated that the crystals were circulating within the drop at an average rotational speed of 64 degrees per second.

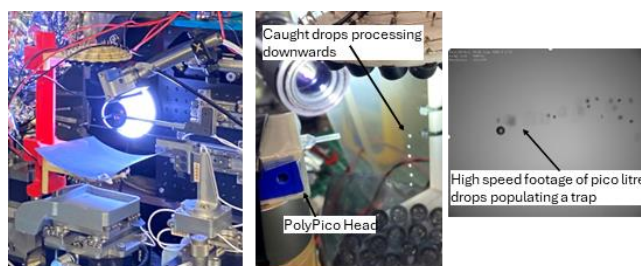

Figure 3. Left, Tinylev on I24 data collection. Middle and Left, Automated sample delivery to Tinylev via a PolyPico delivery system

More recently we have automated this process by loading sample suspensions via a PolyPico system which launches a stream of 50 pL ($\sim 46\mu\text{m}$ diameter) drops that coalesce to larger volumes within traps. The drops need to form a critical volume to remain stable within a trap, see figure 3 with the lowest stably trapped volume achieved thus far estimated at 5 nanolitres.

5. SuperLev, an optimised acoustic trap design

This device is a further iteration of Tinylev to create traps/nodes which can hold material with greater force. It was developed by Bordes et al [8] to improve stability thus increasing applicability for Synchrotron and XFEL experiments. The model tested here is referred to as Mk3 in the previously cited paper and features a significantly smaller footprint (less than 60 mm in the largest dimension) and demonstrates trapping strength in the horizontal and the vertical close to double that of Tinylev. Stability is improved to 10 μm mean horizontal displacement of a 2.0-0.5 μL water droplet. For reference the smallest drop Superlev can hold stably is 5nL which has a nominal radius of 212 μm so 10 μm movement in the horizontal axis is negligible when for example I24's smallest beamline's beam spot 5x5microns is focused at the centre of a levitating drop.

This system is currently being explored on multiple beamlines using techniques such as Small Angle Scattering, Macro Molecular Crystallography on proteins, Small Molecule Single Crystal Diffraction, X-ray Pair Distribution Function, and Powder Diffraction.

6. Results on Beamline I19

On the chemical crystallography beamline (I19), we evaluated the SuperLev system's ability to suspend a crystal in the X-ray beam and collect diffraction data. Using a syringe pump or Poly Pico system, crystals can be loaded and rapidly replenished, offering a promising approach for high-throughput data collection. This method could prove especially advantageous for weakly diffracting crystals, eliminating the need for manual mounting under a microscope. Additionally, the containerless environment provided by SuperLev is ideal for studying nucleation, crystallization, and reaction pathways when mixing reagents.

To calibrate the setup, a 5 μL droplet of Lanthanum Hexaborate (LaB6) powder suspended in a 1% water/surfactant solution was ejected into the SuperLev central trap using a syringe pump (Figure 4a/b). High-resolution powder diffraction patterns were successfully acquired using the Dectris CdTe Eiger 4M detector and used to determine the beam centre and detector distance (Figure 4b). These results also demonstrate the potential of this high-

throughput technique for powder diffraction analysis. The data collection rate was 200 images in 0.1 seconds with 50% transmission. The data was collected for 20 seconds.

In a crystallization experiment, ortho-aminobenzoic acid was dissolved in a 90:10 w/w water mixture and introduced into the SuperLev centre node. As the suspended droplet evaporated, the concentration increased, resulting in microcrystal formation. Diffraction data was continuously collected throughout the evaporation process, with observable diffraction peaks from the forming crystals (Figure 4c). The data collected sufficient for quantitative analysis also highlighting the system's potential for studying nucleation and crystallization in situ. The data collection rate was 200 images in 0.1 seconds with a detector distance of 100 mm, and set at 50% transmission. Data was collected for 20 seconds.

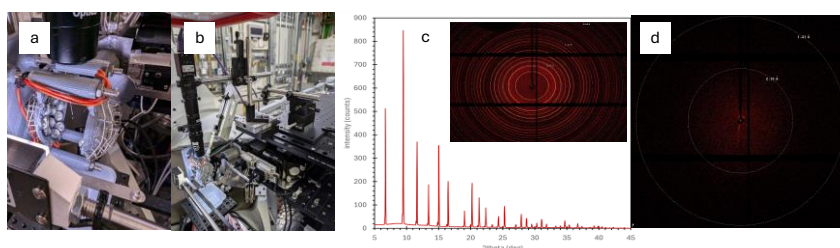

Figure 4. a/b) SuperLev on I19 beamline with a suspended droplet in central node c) suspended droplet of LaB6 powder pattern collected at 0.4859\AA d) diffraction pattern of ortho-aminobenzoic acid crystallised in a suspended droplet.

7. Results on MIRIAM Beamline (B22)

B22 Multimode InfraRed Imaging and Micro-spectroscopy (MIRIAM) is Diamond's Infrared beamline. With an initial set up the first data collection mode tested was IR transmission, however IR spectra were also collected in reflection mode from a Polystyrene bead. Figure 5 shows the set up and an illustrative IR spectrum from the tests. Interestingly the superior lateral forces present in SuperLev enable operation of the levitator horizontally.

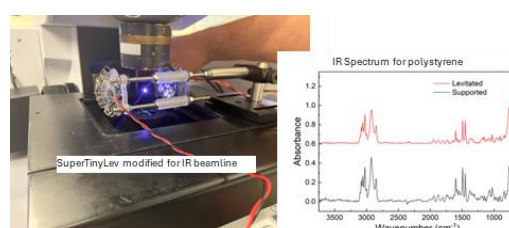

Figure 5. Left, installation for IR measurements on beamline. Right, Spectrum obtained in reflection mode in comparison to conventionally mounted sample. Measurement time = 130 s/spectrum

8. Potential for powder diffraction containerless sample delivery

Two further beamlines, I11 and I15-1 whose key technique is powder diffraction, are reviewing the systems. Key target samples are Metal organic Frameworks (MOFs) with numerous applications including absorption of environmental pollutants. Powdered sample can be held in

space and pollutants introduced within a controlled sample environment and fine changes in structure can then be recorded. The containerless aspect of the acoustic method is of advantage since the traditional method of packing powder into glass capillaries introduces significant background X ray scatter.

9. Conclusions

The broad range of beamlines and scientific techniques described here highlights the applicability and flexibility of acoustics for sample delivery at light sources. The key attributes of being containerless, contact-free, and with the potential for automation, make the approach inviting for many applications. The scope for automation is apparent: using either direct ejection, or device signal phase shift to control the position of acoustic traps to precisely translate a sample into and out of the X-ray beam in free space. Indeed, a combination of delivery to the traps by acoustic ejection or another means such as capillary needle flow is possible. Such set-ups enable hands-free introduction of fresh sample for analysis, increasing throughput and reducing experimenter effort.

For further adoption some aspects of the methods require refinement. Superlev requires the traps to be optimised to ensure optimal sample stability. This is done by ensuring the cavity operates and maintains resonance. By ensuring that opposing transducers are separated by a multiple of their wavelength in air for a given temperature this can be achieved. When resonant the current consumption of the cavity is reduced to a minimum due to the opposing transducers driving each other. This is a good indicator the system is operating optimally. Software upgrades will also be developed to allow greater control of trap strengths, their motion and positioning for data collection. While the PolyPico system is excellent for supplying picolitre discrete drops for many of our applications, to load acoustic traps, a coalescence of drops is required. The authors are testing PolyPico cartridges that can now eject nanolite drops more compatible for acoustic traps.

References

- [1] Gabriel Leen, A New Pico-Litre Fluid Dispensing Technology for New Possibilities, , Biosensors Journal, June 27, 2016, DOI: 10.4172/2090-4967.1000139
- [2] A. Butryn, et al, An on-demand, drop-on-drop method for studying enzyme catalysis by serial crystallography, . *NATURE COMMUNICATIONS* (2021) 12:446, <https://doi.org/10.1038/s41467-021-24757-7>
- [3] B. Davy, et al, Reducing sample consumption for serial crystallography using acoustic drop ejection, J. Synchrotron Rad. (2019). 26, 1820-1825, <https://doi.org/10.1107/S1600577519009329>.
- [4] Elizabeth Galtry, 4 Drop on Demand at EuXFEL Developments in low sample consumption with high beam efficiency systems Poster presentation 3rd standardisation workshop @European XFEL Liquid sample delivery- Experimental Opportunities, European XFEL Hamburg 9-11 December 2024
- [5] Ryuji Hirayama, High-speed acoustic holography with arbitrary scattering objects, Science Advances, 17 Jun 2022, Vol 8, Issue 24 DOI: [10.1126/sciadv.abn7614](https://doi.org/10.1126/sciadv.abn7614)
- [6] Asier Marzo, et al, TinyLev: A multi-emitter single-axis acoustic levitator, 1Rev Sci Instrum 2017 Aug;88(8):085105, <https://doi.org/10.1063/1.4989995>
- [7] R. H. Morris, et al, Non-Contact Universal Sample Presentation for Room Temperature Macromolecular Crystallography Using Acoustic Levitation, , August 2019 Scientific Reports 9(1):1-10, 1 | <https://doi.org/10.1038/s41598-019-48612-4>.
- [8] S. Argyri, et al, Customized and high-performing acoustic levitators for contact-free experiments, Journal of Science: Advanced Materials and Devices, Volume 9, Issue 3, September 2024, 100720, <https://doi.org/10.1016/j.jsamd.2024.100720>